

REVISIONS				
REV.	ECO. NO	DESCRIPTION	DATE	BY
A	2145	INITIAL RELEASE	07/16/2010	LH

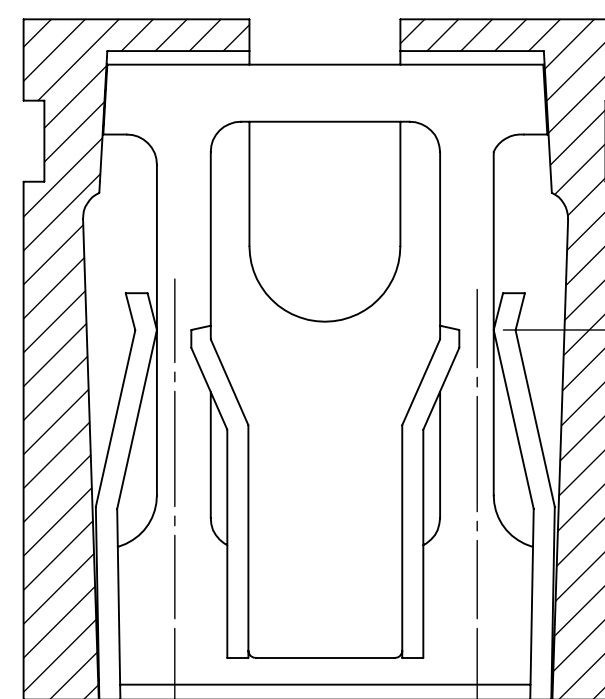

SECTION A-A
SCALE 20 : 1

2X .096 [2.45]
POINT OF CONTACT
(REF.)

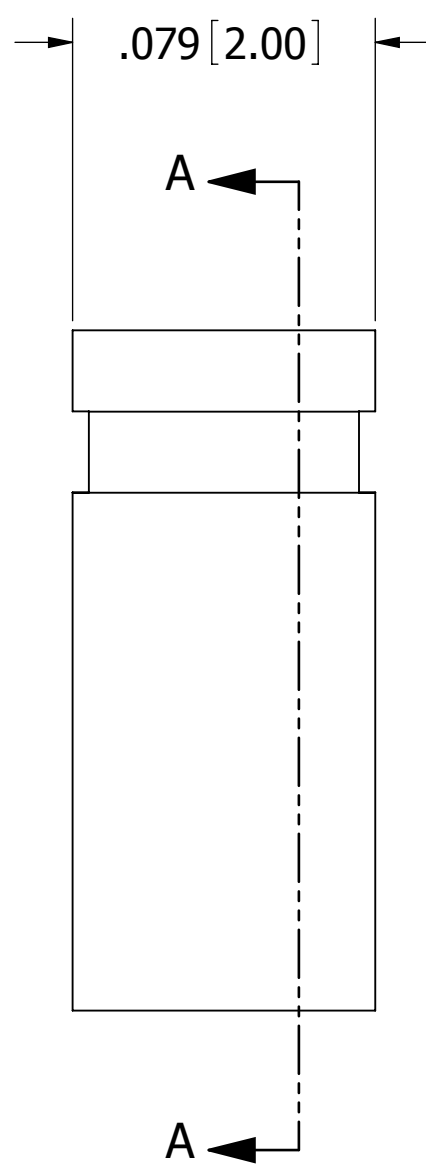
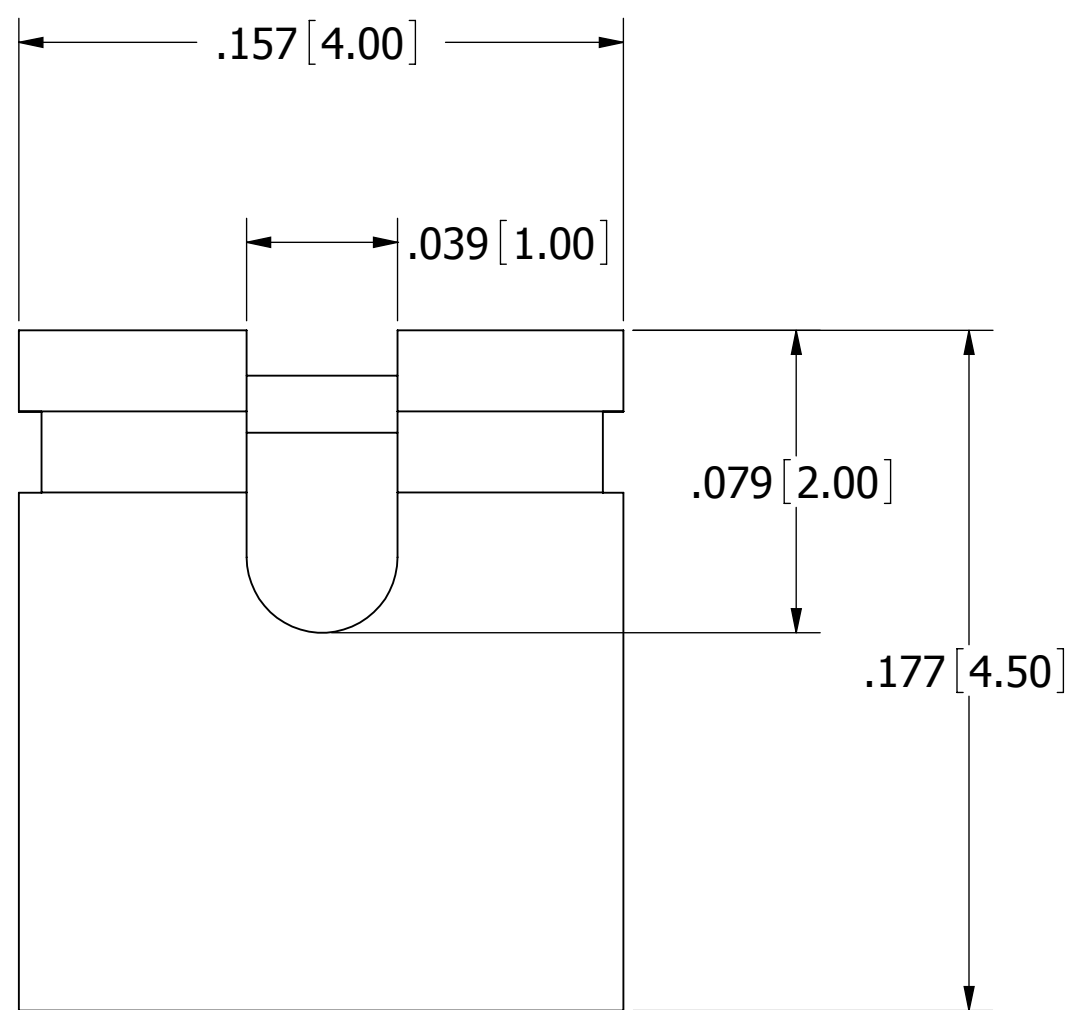
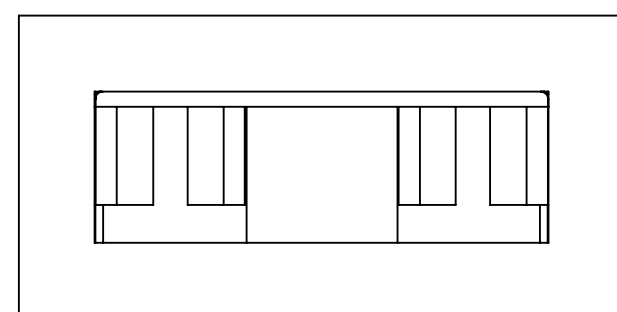
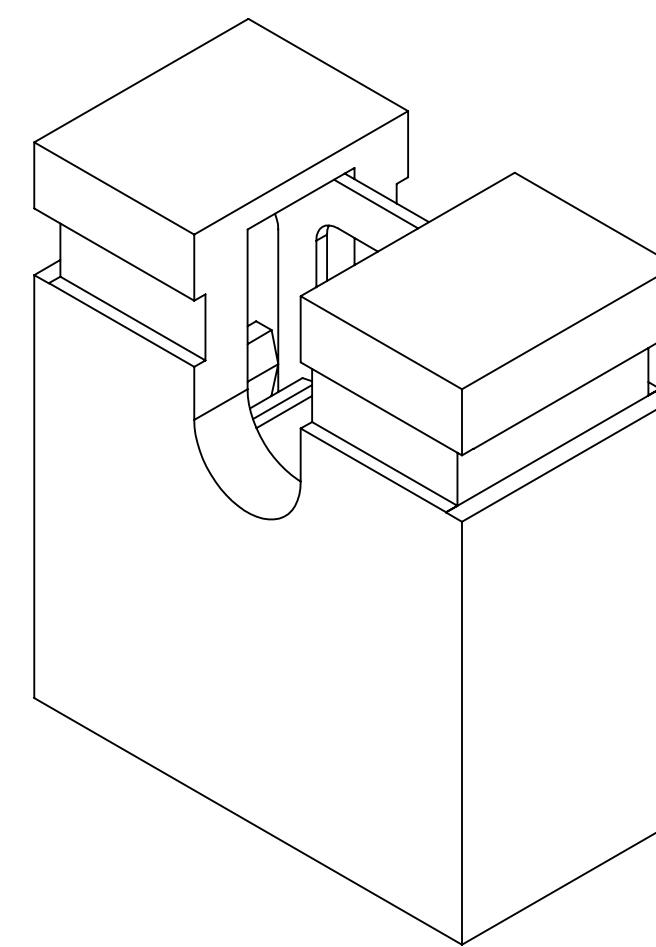

NOTES:

1. INSULATOR MATERIAL: PBT.
2. CONTACT MATERIAL: PHOSPHOR BRONZE.
3. PLATING: GOLD FLASH OVERALL.
4. UL FLAMMABILITY RATING: 94V-0.
5. DIELECTRIC WITHSTANDING VOLTAGE: 650V AC.
6. CURRENT RATING: 1 AMP PER CONTACT.
7. CONTACT RESISTANCE: 30 MILLI OHMS MAX.
8. INSULATION RESISTANCE: 1000 MEGA OHMS.
9. OPERATING TEMPERATURE: -40 °C TO +85 °C.
10. DOUBLE TUNING FORK TYPE CONTACT, ACCOMMODATES .020"[0.50mm] SQ PINS.
.079"[2.00mm] PITCH LOW-PROFILE MINI TYPE.

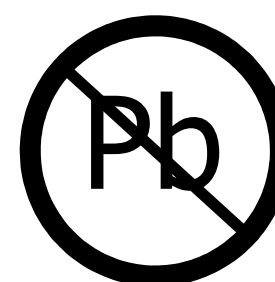

RoHS COMPLIANT

UNLESS OTHERWISE SPECIFIED:
DIMENSIONS ARE IN INCHES[MM]
TOLERANCES:
ANGULAR: ± 30°
.XX=± .012 [.30]
.XXX=± .008 [.20]
.XXXX=± .004 [.10]

INTERPRET DIMENSIONS AND GEOMETRIC
TOLERANCING
PER: ASME Y14.5M-2009

DRAWN	DATE	NAME
LH	7/16/2010	LH

THE INFORMATION HEREIN CONTAINS PROPRIETARY INFORMATION OF SULLINS ELECTRONICS AND IS NOT TO BE REPRODUCED, USED OR DISCLOSED TO OTHERS FOR ANY PURPOSE EXCEPT AS SPECIFICALLY AUTHORIZED IN WRITING BY AN OFFICER OF SULLINS ELECTRONICS.

DESCRIPTION MINI SHUNT, .079" CC, OPEN TOP		
PART NUMBER SPN02SXCN-RC		
SIZE	DWG. NO.	REV
C	11504	A
SCALE: 16:1		SHEET 1 OF 1