

REVISIONS				
REV.	ECO. NO	DESCRIPTION	DATE	BY
A	1521	INITIAL RELEASE	10/3/2007	VJ
B	2147	ADD 47 & 50 POSITIONS	6/03/2010	JH

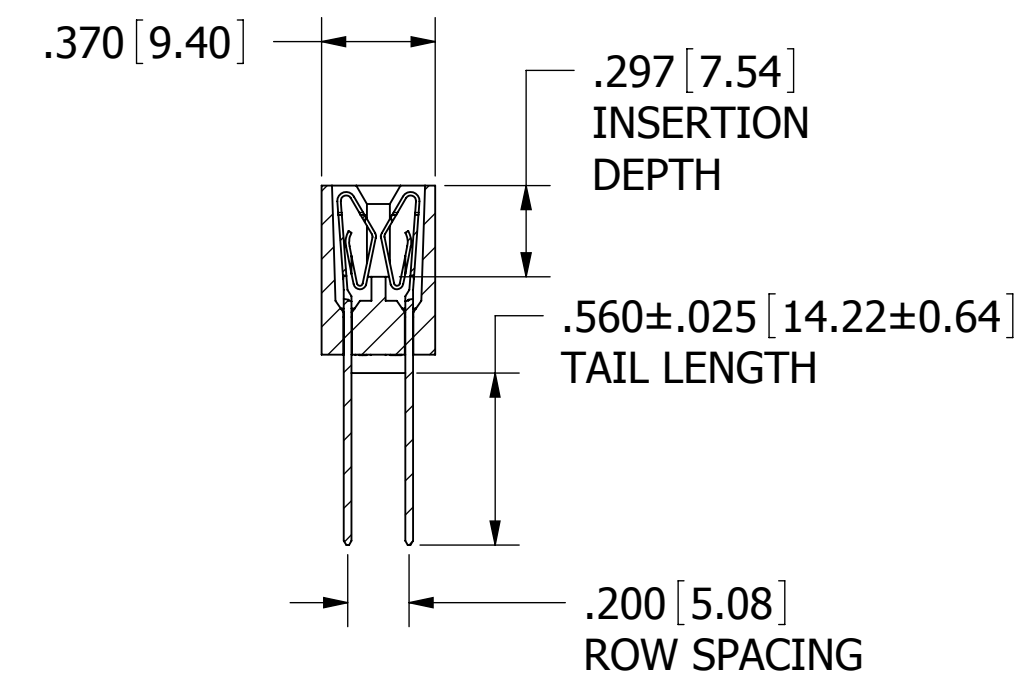

--- M --- DRMH

SECTION A-A

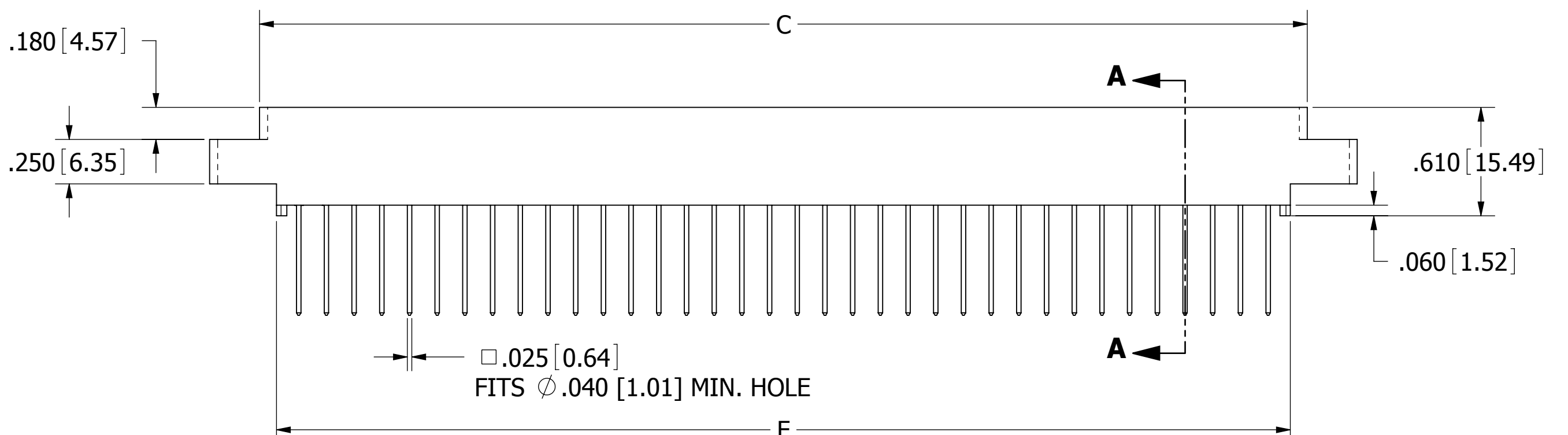
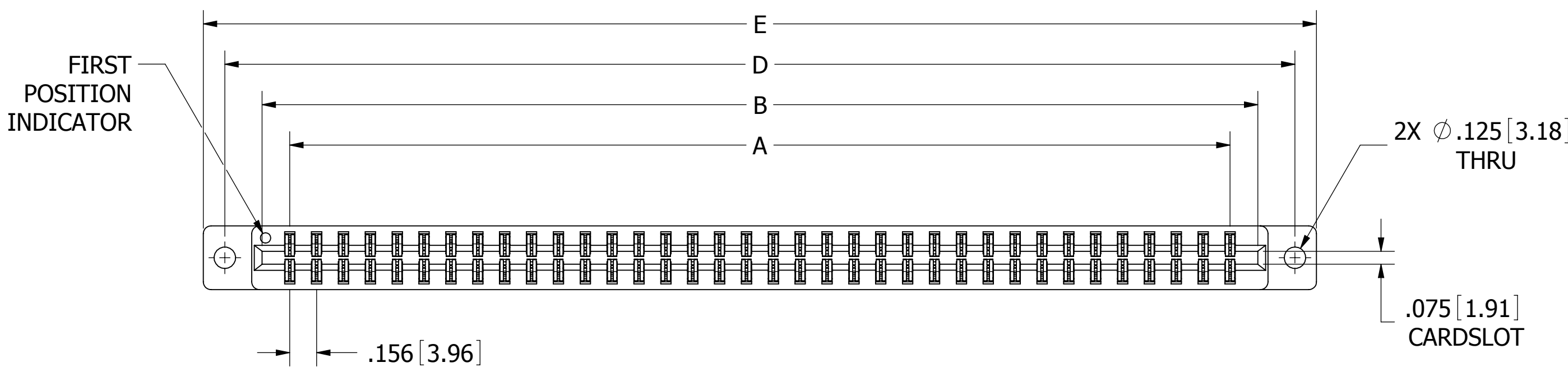
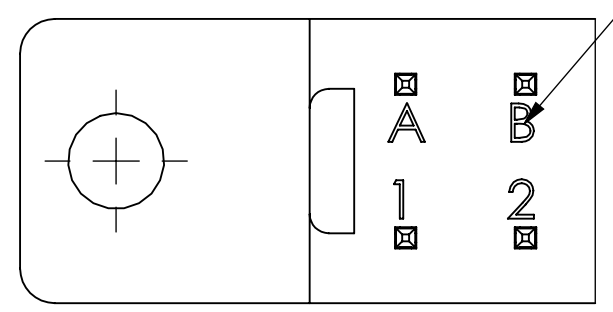

CONTACT ID  
SCALE 4:1

CONTACT MARKINGS  
(LETTERS G, I, O & Q NOT USED)

SIZES 06-25 & 30  
1 2 ... 23 24 ... 29 30  
A B ... A B ... H J

SIZES 28 & 31  
1 2 ... 23 24 ... 30 31  
A B ... A B ... J K

SIZES 36 - 43  
A B ... A B ... X Y  
1 2 ... 23 24 ... 42 43

SIZES 47 & 50  
1 3 ... 97 99  
2 4 ... 98 100

- NOTES:
1. INSULATOR MATERIAL: SEE PART NUMBER CODING.
  2. CONTACT MATERIAL: SEE PART NUMBER CODING.
  3. PLATING: SEE PART NUMBER CODING.
  4. OPERATING TEMPERATURE: SEE PART NUMBER CODING.
  5. PROCESSING TEMP: SEE PART NUMBER CODING.
  6. UL FLAMMABILITY RATING: 94V-0.
  7. VOLTAGE RATING: 950 VAC MINIMUM AT SEA LEVEL.
  8. CURRENT RATING: 3 AMP PER CONTACT.
  9. CONTACT RESISTANCE: 30 MILLI OHMS MAX.
  10. INSULATION RESISTANCE: 5000 MEGA OHMS.
  11. DURABILITY: 500 CYCLES MIN.
  12. CONNECTOR IDENTIFICATION: THE PART SHALL BE MARKED WITH A PART NUMBER AND BARCODE.
  13. BOARD THICKNESS ACCOMMODATED: .062 ± .008 [1.57 ± 0.20].
  14. BOARD INSERTION FORCE: 16 OZ MAX PER CONTACT PAIR WHEN USING A .062 [1.57] TEST BLADE. INTERNAL INSPECTION TO BE PER SULLIN'S WORK INSTRUCTION W17.3-01.
  15. BOARD WITHDRAWAL FORCE: 1 OUNCE MINIMUM PER CONTACT PAIR USING .062 [1.57] PCB.



**CUSTOMER COPY**

UNLESS OTHERWISE SPECIFIED: DIMENSIONS ARE IN INCHES[MM] TOLERANCES: ANGULAR: ± 30' .XX=± .02 [508] .XXX=± .005 [1270] .XXXX=± .0005 [127] SURFACE FINISH: 63 Rg REMOVE ALL BURRS AND SHARP EDGES .010 MAX		DATE 10/3/2007	NAME V. JARA	
THE INFORMATION HEREIN CONTAINS PROPRIETARY INFORMATION OF SULLINS ELECTRONICS AND IS NOT TO BE REPRODUCED, USED OR DISCLOSED TO OTHERS FOR ANY PURPOSE EXCEPT AS SPECIFICALLY AUTHORIZED IN WRITING BY AN OFFICER OF SULLINS ELECTRONICS.		DESCRIPTION EDGECARD, .156 CC, HP		
INTERPRET DIMENSIONS AND GEOMETRIC TOLERANCING PER: ANSI Y14.5M-1994		SIZE C	DWG. NO. C10976	REV B
		SCALE: 2:1		SHEET 1 OF 3

8 7 6 5 4 3 2 1

F  
E  
D  
C  
B  
A

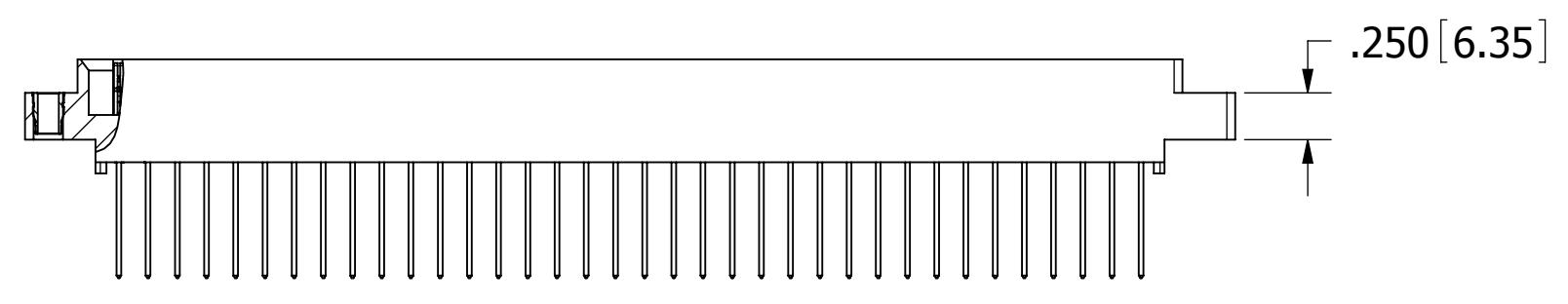
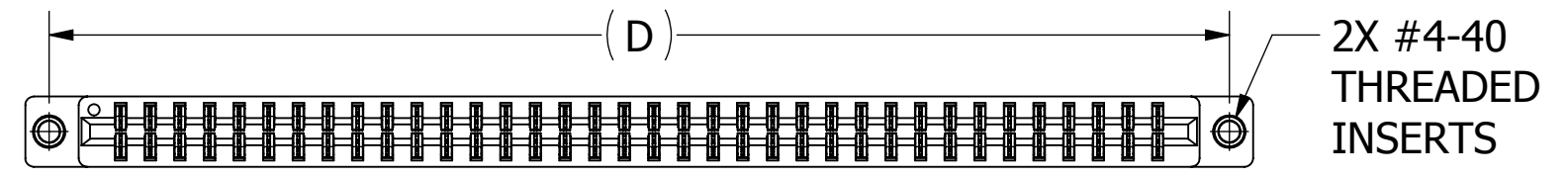

**\_\_ M \_\_ DRMI**

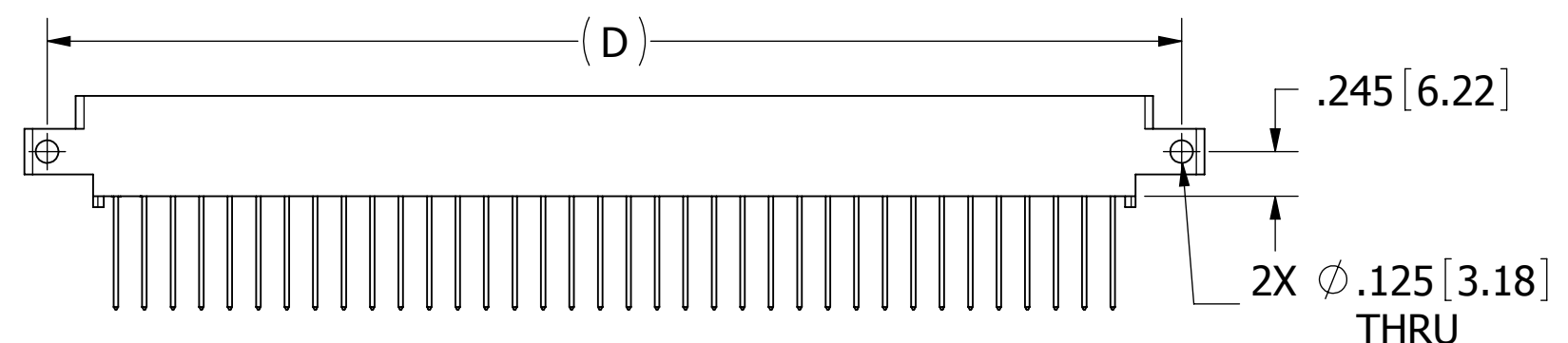
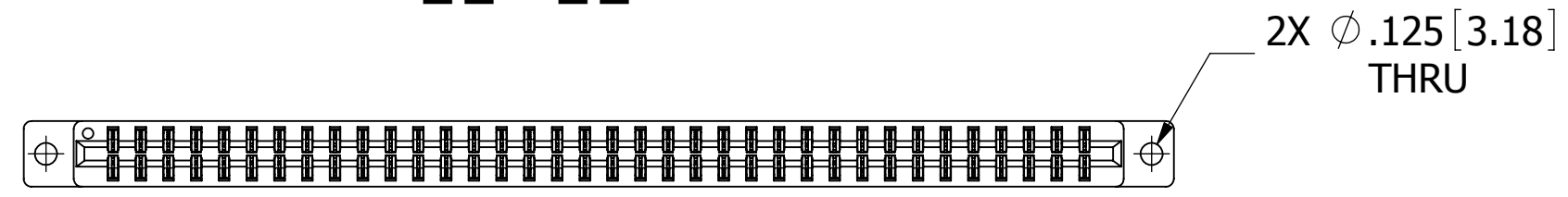

**\_\_ M \_\_ DRMS**

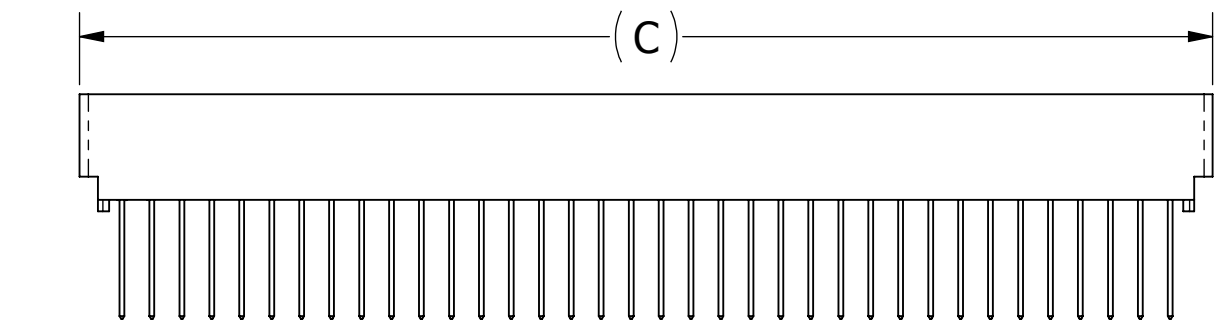
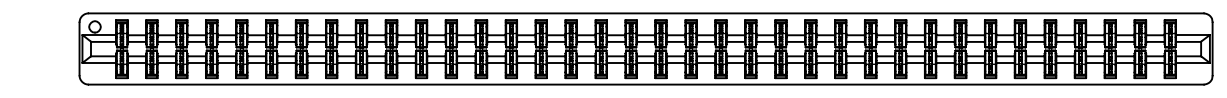

**\_\_ M \_\_ DRMN**

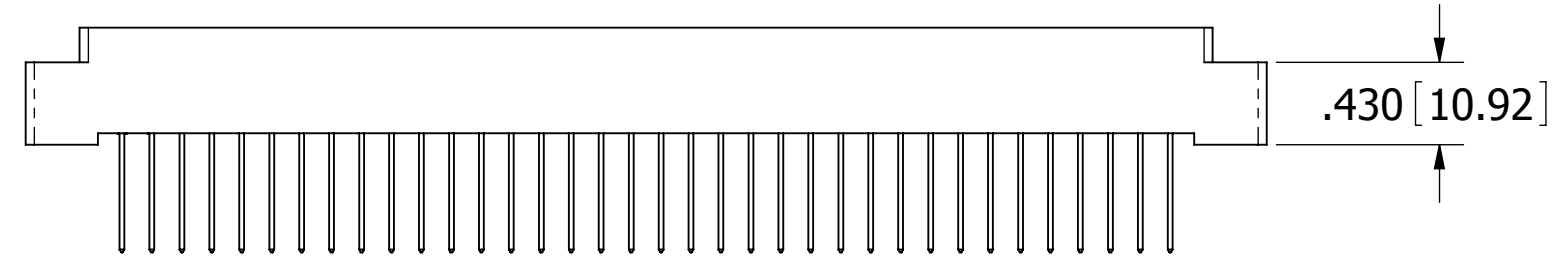
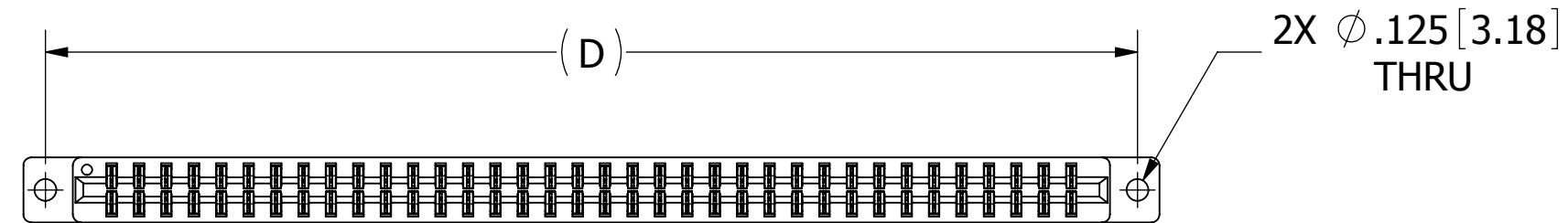

**\_\_ M \_\_ DRMT**

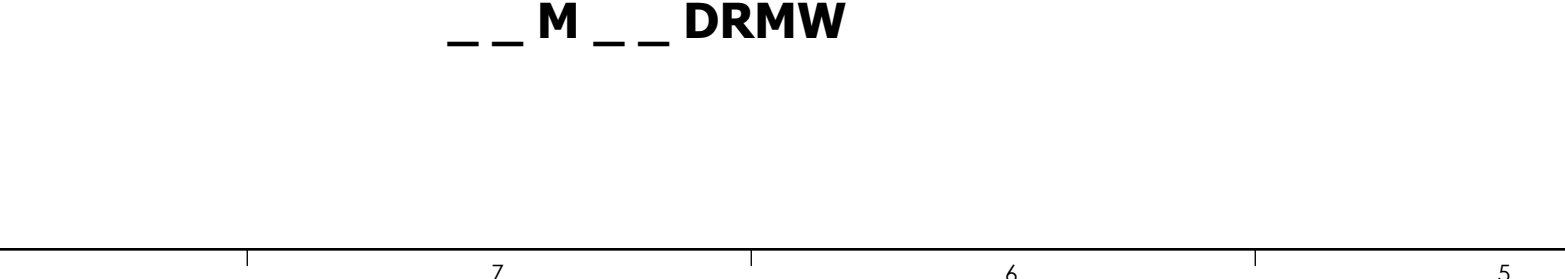

**\_\_ M \_\_ DRMW**

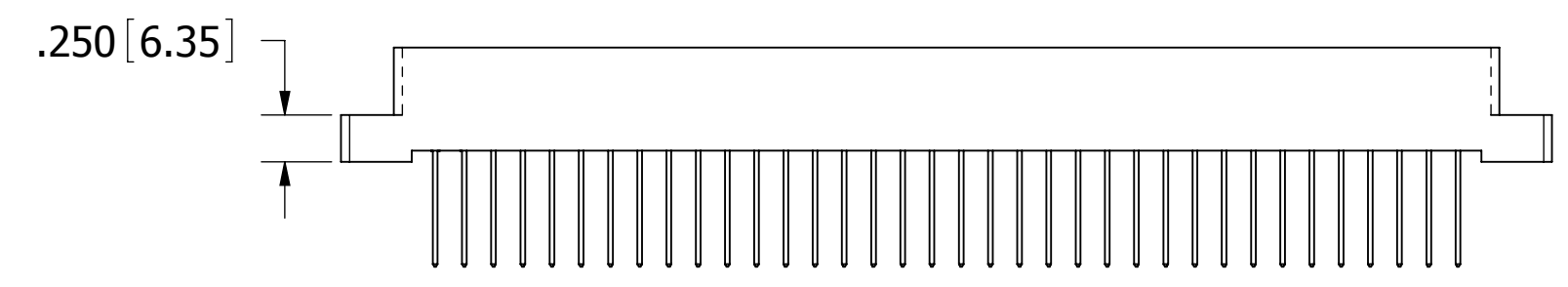
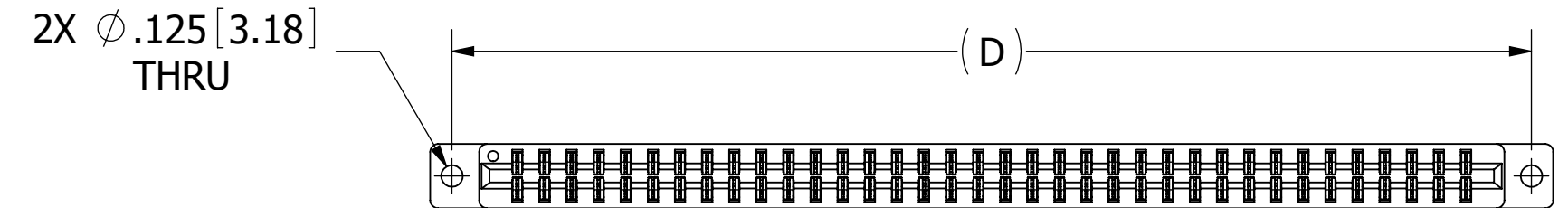

**\_\_ M \_\_ DRMD**

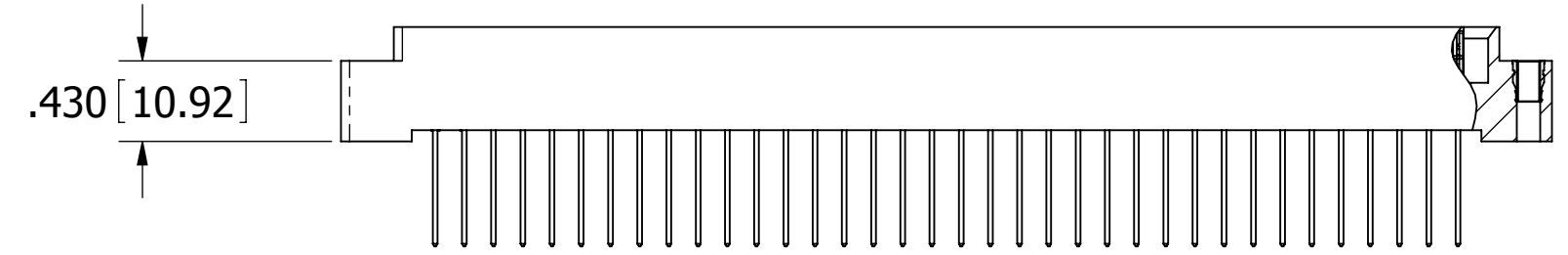
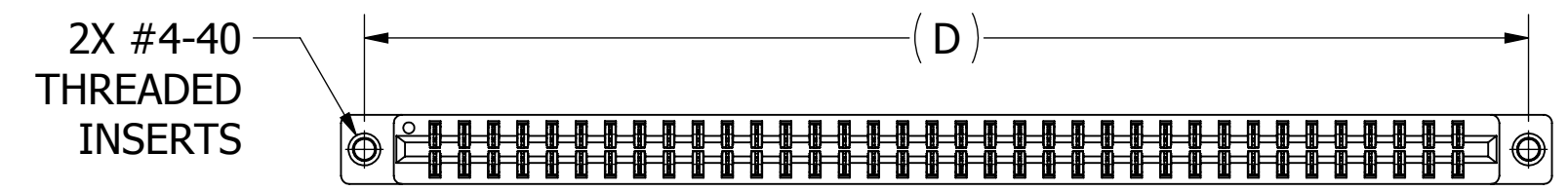

**\_\_ M \_\_ DRMX**

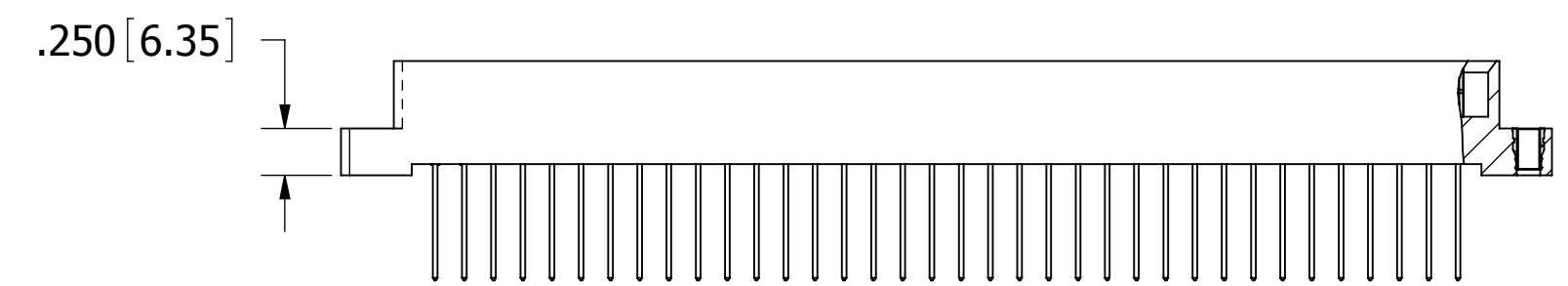
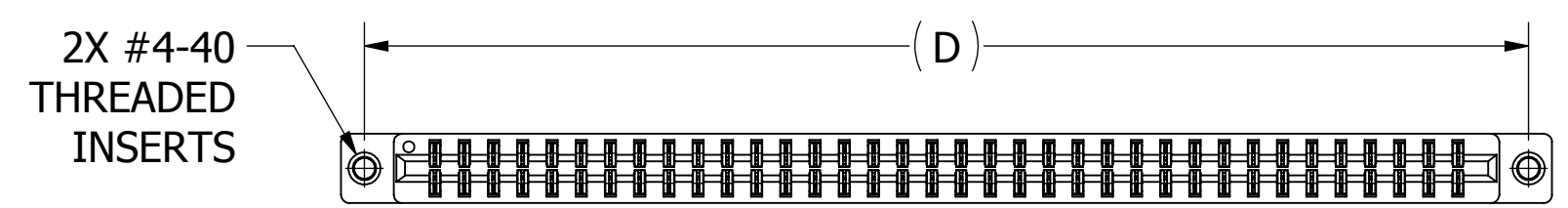

**\_\_ M \_\_ DRMT**

**CUSTOMER COPY**

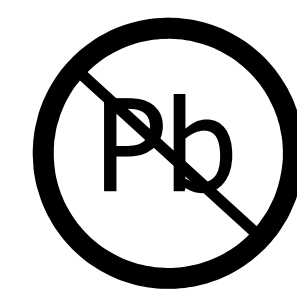

**RoHS COMPLIANT**

UNLESS OTHERWISE SPECIFIED:  
 DIMENSIONS ARE IN INCHES[MM]  
 TOLERANCES:  
 ANGULAR: ± 30'  
 .XX=± .02 [.508]  
 .XXX=± .005 [.1270]  
 .XXXX=± .0005 [.0127]  
 SURFACE FINISH: 63 Rc  
 REMOVE ALL BURRS AND SHARP EDGES .010 MAX

INTERPRET DIMENSIONS AND GEOMETRIC TOLERANCING PER: ANSI Y14.5M-1994

DRAWN	10/3/2007	V. JARA	DATE	NAME
THE INFORMATION HEREIN CONTAINS PROPRIETARY INFORMATION OF SULLINS ELECTRONICS AND IS NOT TO BE REPRODUCED, USED OR DISCLOSED TO OTHERS FOR ANY PURPOSE EXCEPT AS SPECIFICALLY AUTHORIZED IN WRITING BY AN OFFICER OF SULLINS ELECTRONICS.				
DESCRIPTION EDGE CARD, .156 CC, HP			SULLINS CONNECTOR SOLUTIONS	
PART NUMBER __ M __ DRM __			SIZE DWG. NO. C C10976	
SCALE: 1:1			REV B	
SHEET 2 OF 3				

PART NUMBER	NO. OF POS.	INCHES						MILLIMETERS					
		A±.008	B±.008	C±.015	D±.010	E±.020	F±.015	A±0.20	B±0.20	C±0.38	D±0.25	E±0.51	F±0.38
_ _ M06DRM _ _	6	0.780	1.102	1.221	1.534	1.784	1.030	19.81	27.99	31.01	38.96	45.31	26.16
_ _ M08DRM _ _	8	1.092	1.414	1.533	1.846	2.096	1.342	27.74	35.92	38.94	46.89	53.24	34.09
_ _ M10DRM _ _	10	1.404	1.726	1.845	2.158	2.408	1.654	35.66	43.84	46.86	54.81	61.16	42.01
_ _ M12DRM _ _	12	1.716	2.038	2.157	2.470	2.720	1.966	43.59	51.77	54.79	62.74	69.09	49.94
_ _ M15DRM _ _	15	2.184	2.506	2.625	2.938	3.188	2.434	55.47	63.65	66.68	74.63	80.98	61.82
_ _ M18DRM _ _	18	2.652	2.974	3.093	3.406	3.656	2.902	67.36	75.54	78.56	86.51	92.86	73.71
_ _ M20DRM _ *	20	2.964	3.286	3.405	3.718	3.968	3.214	75.29	83.46	86.49	94.44	100.79	81.64
_ _ M22DRM _ _	22	3.276	3.598	3.717	4.030	4.280	3.526	83.21	91.39	94.41	102.36	108.71	89.56
_ _ M24DRM _ _	24	3.588	3.910	4.029	4.342	4.592	3.838	91.14	99.31	102.34	110.29	116.64	97.49
_ _ M25DRM _ _	25	3.744	4.066	4.185	4.498	4.748	3.994	95.10	103.28	106.30	114.25	120.60	101.45
_ _ M28DRM _ _	28	4.212	4.534	4.653	4.966	5.216	4.462	106.98	115.16	118.19	126.14	132.49	113.33
_ _ M30DRM _ _	30	4.524	4.846	4.965	5.278	5.528	4.774	114.91	123.09	126.11	134.06	140.41	121.26
_ _ M31DRM _ _	31	4.680	5.002	5.121	5.434	5.684	4.930	118.87	127.05	130.07	138.02	144.37	125.22
_ _ M36DRM _ _	36	5.460	5.782	5.901	6.214	6.464	5.710	138.68	146.86	149.89	157.84	164.19	145.03
_ _ M40DRM _ _	40	6.084	6.406	6.525	6.838	7.088	6.334	154.53	162.71	165.74	173.69	180.04	160.88
_ _ M43DRM _ _	43	6.552	6.874	6.993	7.306	7.556	6.802	166.42	174.60	177.62	185.57	191.92	172.77
_ _ M47DRM _ _	47	7.176	7.498	7.617	7.930	8.180	7.426	182.27	190.45	193.47	201.42	207.77	188.62
_ _ M50DRM _ _	50	7.644	7.966	8.085	8.398	8.648	7.894	194.16	202.34	205.36	213.31	219.66	200.51

\* CONSULT FACTORY FOR AVAILABILITY

### PART NUMBER CODING

#### MATERIALS (INSULATOR / CONTACT)

##### E = PBT/PHOSPHOR BRONZE

OPERATING TEMP: -65°C TO +125°C  
PROCESSING TEMP: 260°C FOR 10 SECS MAX

##### R = PPS/PHOSPHOR BRONZE

OPERATING TEMP: -65°C TO +125°C  
PROCESSING TEMP: 260°C FOR 120 SECS MAX

##### G = PA9T/PHOSPHOR BRONZE

OPERATING TEMP: -65°C TO +125°C  
PROCESSING TEMP: 260°C FOR 120 SECS MAX

##### A = PPS/BERYLLIUM COPPER

OPERATING TEMP: -65°C TO +150°C  
PROCESSING TEMP: 260°C FOR 120 SECS MAX

##### J = PA9T/BERYLLIUM COPPER

OPERATING TEMP: -65°C TO +150°C  
PROCESSING TEMP: 260°C FOR 120 SECS MAX

(CONSULT FACTORY FOR OTHER MATERIALS)

#### PLATING

ALL PLATINGS ARE LEAD FREE AND HAVE .000050" NICKEL UNDERPLATE

##### CONTACT SURFACE

G = .000010" GOLD

Y = .000030" GOLD

B = .000010" GOLD

C = .000030" GOLD

\*\*E = .000100" PURE TIN, MATTE, OVERALL

S = .000010" GOLD OVERALL

M = .000030" GOLD

\*\* OVERALL PURE TIN ONLY AVAILABLE ON MATERIAL CODES E, R AND G

#### MOUNTING STYLE

H = .125" DIA. CLEARANCE HOLES (PAGE 1)

I = #4-40 THREADED INSERT (PAGE 2)

S = .125" DIA. SIDE MOUNTING (PAGE 2)

N = NO MOUNTING EARS (PAGE 2)

D = FLUSH MOUNTING (PAGE 2)

W = FLUSH MOUNTING (PAGE 2)

X = FLUSH MOUNTING WITH # 4-40 THREADED INSERT (PAGE 2)

T = FLUSH MOUNTING WITH # 4-40 THREADED INSERT (PAGE 2)

#### NUMBER OF POSITIONS (CONTACTS PER ROW)

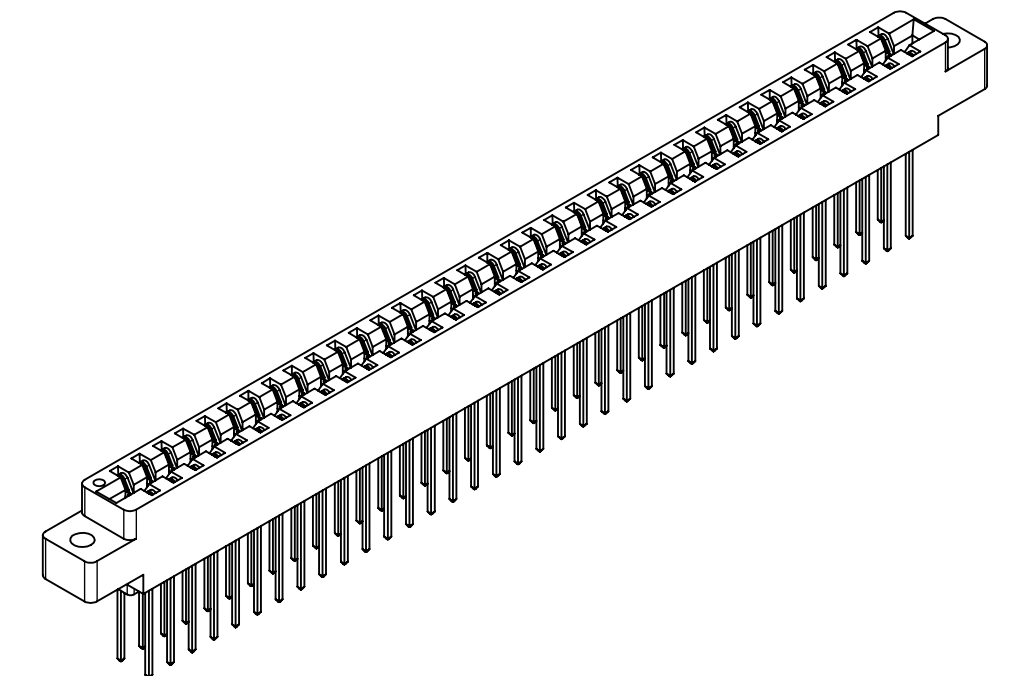

## CUSTOMER COPY

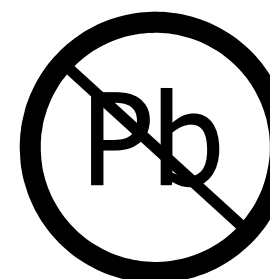

RoHS COMPLIANT

UNLESS OTHERWISE SPECIFIED:  
DIMENSIONS ARE IN INCHES[MM]  
TOLERANCES:  
ANGULAR: ± 30'  
.XX=± .02 [.508]  
.XXX=± .005 [.1270]  
.XXXX=± .0005 [.0127]  
SURFACE FINISH: 63 R<sub>a</sub>  
REMOVE ALL BURRS AND SHARP EDGES .010 MAX

INTERPRET DIMENSIONS AND GEOMETRIC TOLERANCING PER: ANSI Y14.5M-1994

DRAWN	DATE	NAME	
	10/3/2007	V. JARA	
<small>THE INFORMATION HEREIN CONTAINS PROPRIETARY INFORMATION OF SULLINS ELECTRONICS AND IS NOT TO BE REPRODUCED, USED OR DISCLOSED TO OTHERS FOR ANY PURPOSE EXCEPT AS SPECIFICALLY AUTHORIZED IN WRITING BY AN OFFICER OF SULLINS ELECTRONICS.</small>			DESCRIPTION
			EDGE CARD, .156 CC, HP
PART NUMBER			
_ _ M _ _ DRM _ _			
SIZE	DWG. NO.	REV	
C	C10976	B	
SCALE: 2:1			SHEET 3 OF 3